

Model 1250
One Conductor,
250 Amp

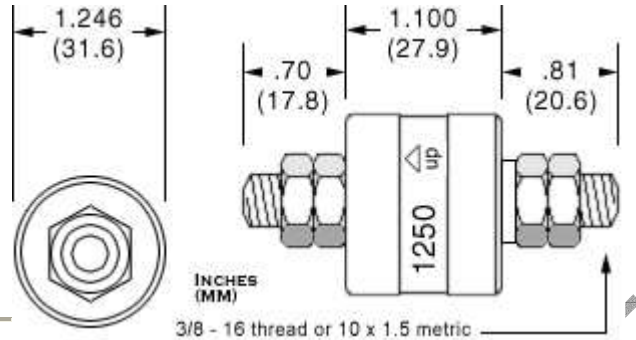

4 jam nuts included

Boot kit available

Available in metric thread (1250-M)

Available with stainless steel ball bearings (1250-SS) (recommended for wet or corrosive environments)

Available with stainless steel body and bearing (1250-SX / 1250-MSX) (recommended for wet or corrosive environments)

Model No.	Terminals	Voltage AC/DC	Amp Rating @240VAC	Max. Freq. MHz	Contact Resistance	Max. RPM	Temp Max. F (C) / Min. F (C)	Rotation Torque (gm-cm)	Circuit Separation
1250	1	N/A	250	200	<1m Ω	1200	140 (60) /- 20(-29)	250	N/A
1250-SS	1	N/A	250	200	<1m Ω	1200	140 (60) /- 20(-29)	250	N/A
1250-M	1	N/A	250	200	<1m Ω	1200	140 (60) /- 20(-29)	250	N/A
1250-MS	1	N/A	250	200	<1m Ω	1200	140 (60) /- 20(-29)	250	N/A
1250-SX	1	N/A	250	200	<1m Ω	1200	140 (60) /- 20(-29)	250	N/A
1250-MSX	1	N/A	250	200	<1m Ω	1200	140 (60) /- 20(-29)	250	N/A

"SS" designator indicates stainless steel ball bearing

"M" designator indicates metric thread (10 x 1.5)

"MS" designator indicates metric thread & stainless steel ball bearing

"SX" designator indicates stainless steel body & bearing

"MSX" designator indicates metric thread & stainless steel body & bearing

Note: The anodized aluminum housing of the 1250 series Mercotac is electrically "hot" to the internal conductor.

1250 Accessories



57125

Book Kit for dust and splash protection
IP51

1250 Connections

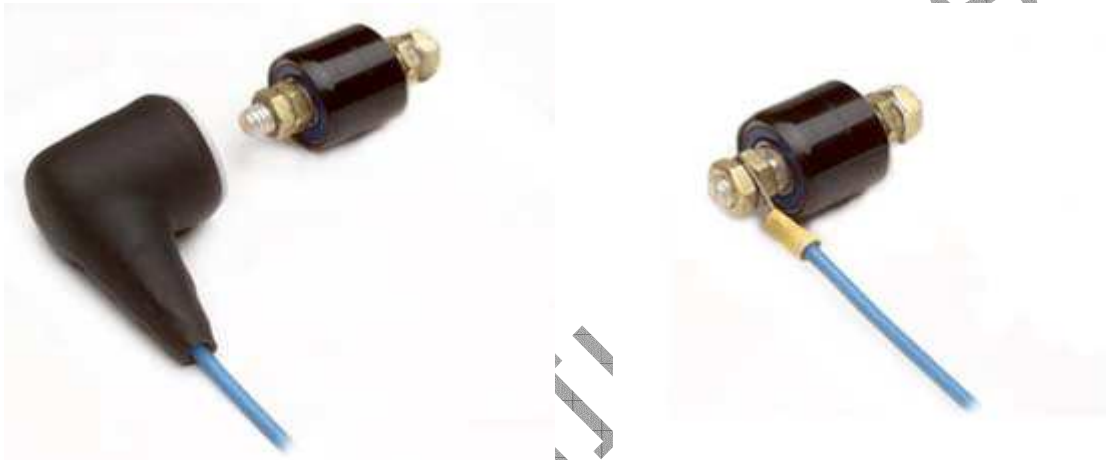

1250 Suggested Mounting Methods

Model 1250 is typically mounted by the threaded stud on either end or by the black body using a set screw. When mounting horizontally, mount the Mercotac so the body of the connector rotates.

Typical Body Mount Dimensions

MODEL	HOLE DIAMETER (Ø) *	DEPTH
1250 et al	1.248" (31.70)	.80" (20.0)

Typical Threaded Contact Mount

1250 (inch)	3/8 - 16 UNC	.81" (20.5)
1250 (metric)	M10 X 1.5	.81" (20.5)

*Inch (mm) Tolerance
 Ø +.001" (+.025)
 -.000" (-.000)

--	--

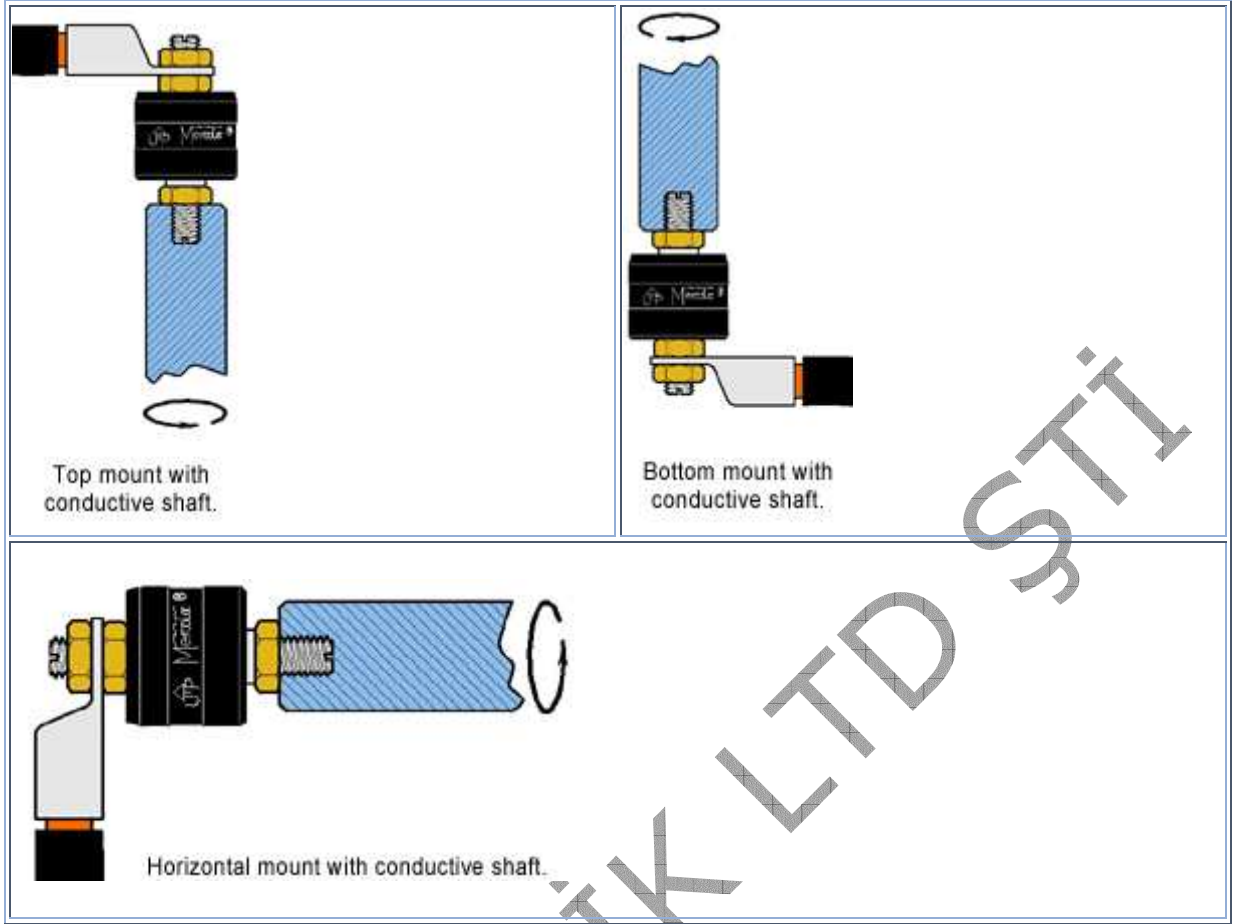

Installation Notes:

- the up arrow should not point below horizontal
- do not solder to or bend connector tabs
- avoid lateral forces and mechanical loads (overly stiff or tight wires)
- do not rigid mount both ends of connector
- limit mounting eccentricity (runout / wobble) to .005" (.13mm)
- provide overload protection within the circuit
- avoid vibration and bumping motions



İmaj Teknik Elektrik Elektronik San. ve Tic. Ltd. Şti.

EMEKYEMEZ MAH.TUTSAK SOK. NO: 16/13-14-15
KARAKOY/İSTANBUL
TURKEY

Telefon : +90 212 235 9535 / 36
Fax : +90 212 235 9537

www.imajteknik.com
www.imajteknik.com.tr